

**Features**

- 2-channel isolated barrier
- 24 V DC supply (Power Rail)
- Dry contact or NAMUR inputs
- 2 x 2 relay contact outputs with AND logic
- Line fault detection (LFD)
- Reversible mode of operation
- Up to SIL2 acc. to IEC 61508

**Function**

This isolated barrier is used for intrinsic safety applications. It transfers digital signals (NAMUR sensors/mechanical contacts) from a hazardous area to a safe area.

Each sensor or switch controls two form A normally open relay contacts for the safe area load. The normal output state can be reversed using switches S1 and S2. Switch S3 is used to enable or disable line fault detection of the field circuit.

During an error condition, the relays revert to their de-energized state and the LEDs indicate the fault according to NAMUR NE44.

A unique collective error messaging feature is available when used with the Power Rail system.

**Assembly**

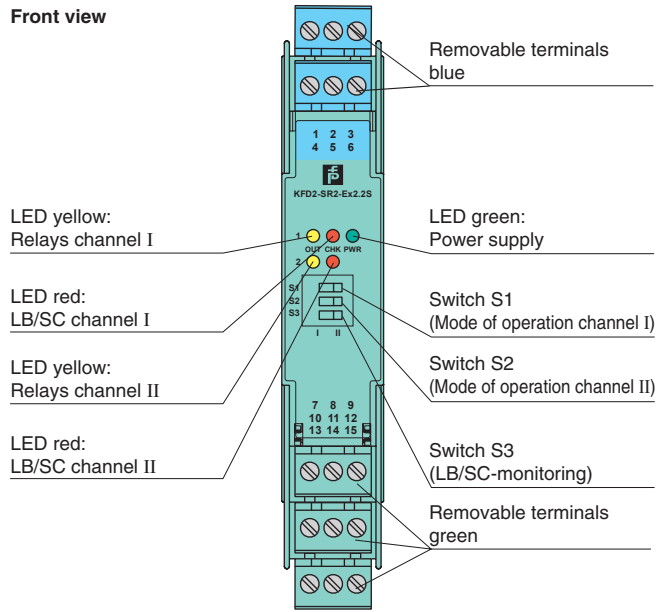

**Connection**

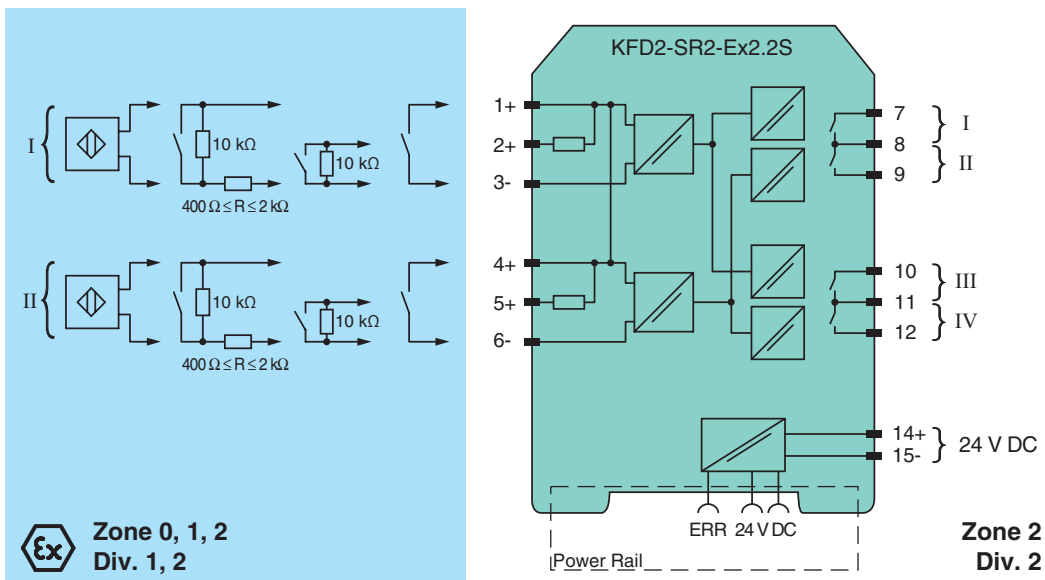

Release date 2010-02-02 18:14 Date of issue 2011-11-21 181284\_eng.xml

<b>General specifications</b>	
Signal type	Digital Input
<b>Supply</b>	
Connection	Power Rail or terminals 14+, 15-
Rated voltage	20 ... 30 V DC
Ripple	≤ 10 %
Rated current	≤ 50 mA
Power loss	1 W
Power consumption	< 1.3 W
<b>Input</b>	
Connection	terminals 1+, 2+, 3-; 4+, 5+, 6-
Rated values	acc. to EN 60947-5-6 (NAMUR)
Open circuit voltage/short-circuit current	approx. 8 V DC / approx. 8 mA
Switching point/switching hysteresis	1.2 ... 2.1 mA / approx. 0.2 mA
Line fault detection	breakage I ≤ 0.1 mA , short-circuit I > 6 mA
Pulse/Pause ratio	≥ 20 ms / ≥ 20 ms
<b>Output</b>	
Connection	output I: terminals 7, 8 ; output II: terminals 8, 9 ; output III: terminals 10, 11 ; output IV: terminals 11, 12
Collective error message	Power Rail
Output I, II, III, IV	channel 1, 2; relay
Contact loading	50 V AC/1 A/cos φ > 0.7; 40 V DC/1 A resistive load
Minimum switch current	1 mA / 24 V DC
Energized/De-energized delay	approx. 20 ms / approx. 20 ms
Mechanical life	10 <sup>8</sup> switching cycles
<b>Transfer characteristics</b>	
Switching frequency	≤ 10 Hz
<b>Electrical isolation</b>	
Output/power supply	basic insulation according to IEC 61140, rated insulation voltage 50 V <sub>eff</sub>
Output/Output	basic insulation according to IEC 61140, rated insulation voltage 50 V <sub>eff</sub>
<b>Directive conformity</b>	
Electromagnetic compatibility	
Directive 2004/108/EC	EN 61326-1:2006
Low voltage	
Directive 2006/95/EC	EN 50178:1997
<b>Conformity</b>	
Electromagnetic compatibility	NE 21
Protection degree	IEC 60529
Protection against electric shock	IEC 61140
<b>Ambient conditions</b>	
Ambient temperature	-20 ... 60 °C (-4 ... 140 °F)
<b>Mechanical specifications</b>	
Protection degree	IP20
Mass	approx. 150 g
Dimensions	20 x 119 x 115 mm (0.8 x 4.7 x 4.5 in) , housing type B2
<b>Data for application in connection with Ex-areas</b>	
EC-Type Examination Certificate	PTB 00 ATEX 2083 , for additional certificates see www.pepperl-fuchs.com
Group, category, type of protection	⊕ II (1)GD [EEx ia] IIC [circuit(s) in zone 0/1/2]
Input	EEx ia IIC
Voltage U <sub>o</sub>	10.5 V
Current I <sub>o</sub>	13 mA
Power P <sub>o</sub>	34 mW (linear characteristic)
Supply	
Maximum safe voltage U <sub>m</sub>	253 V AC / 125 V DC (Attention! U <sub>m</sub> is no rated voltage.)
Output	
Contact loading	50 V AC/1 A/cos φ > 0.7; 40 V DC/1 A resistive load
Maximum safe voltage U <sub>m</sub>	253 V AC (Attention! The rated voltage can be lower.)
Statement of conformity	
Group, category, type of protection, temperature class	⊕ II 3G Ex nA nC IIC T4
Electrical isolation	
Input/input	not available
Input/Output	safe galvanic isolation acc. to EN 50020, voltage peak value 375 V
Input/power supply	safe galvanic isolation acc. to EN 50020, voltage peak value 375 V
Directive conformity	

Release date 2010-02-02 18:14 Date of issue 2011-11-21 181284\_eng.xml

Directive 94/9/EC	EN 50014, EN 50020 , EN 60079-0:2006, EN 60079-15:2005
<b>International approvals</b>	
FM approval	
Control drawing	116-0035
CSA approval	
Control drawing	116-0047
<b>General information</b>	
Supplementary information	EC-Type Examination Certificate, Statement of Conformity, Declaration of Conformity, Attestation of Conformity and instructions have to be observed where applicable. For information see <a href="http://www.pepperl-fuchs.com">www.pepperl-fuchs.com</a> .

**Configuration**

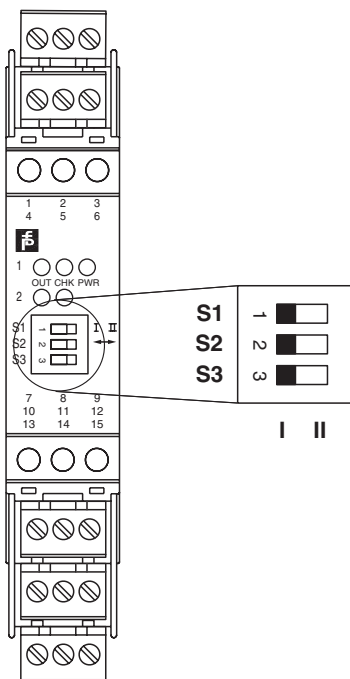

**Switch position**

S	Function		Position
1	Mode of operation Channel I (relay) energized	with high input current	I
		with low input current	II
2	Mode of operation Channel II (relay) energized	with high input current	I
		with low input current	II
3	Line fault detection	ON	I
		OFF	II

**Operating status**

Control circuit	Input signal
Initiator high impedance/ contact opened	low input current
Initiator low impedance/ contact closed	high input current
Lead breakage, lead short-circuit	Line fault

Factory settings: switch 1, 2 and 3 in position I

**Accessories**

**Power feed modules KFD2-EB2...**

The power feed module is used to supply the devices with 24 V DC via the Power Rail. The fuse-protected power feed module can supply up to 100 individual devices depending on the power consumption of the devices. A galvanically isolated mechanical contact uses the Power Rail to transmit collective error messages.

**Power Rail UPR-03**

The Power Rail UPR-03 is a complete unit consisting of the electrical inset and an aluminium profile rail 35 mm x 15 mm. To make electrical contact, the devices are simply engaged.

**The Power Rail must not be fed via the device terminals of the individual devices!**