

Trusted Dual 24 Vdc Digital Input Module - 60 Channel

Product Overview

The Trusted® Dual 24 Vdc Digital Input Module interfaces to 60 field input devices. Fault tolerance is achieved through the 'One-Out Of-Two D' (1oo2D) voting architecture within the Module for each of the 60 input channels.

Each field input is duplicated and the input voltages are measured using sigma-delta input circuits. The resulting field voltage measurement is compared to user configurable threshold voltages to determine the reported field input state. When a line-monitoring device is installed at the field switch, the Module can detect open and short circuit field cables. Line monitoring functions are independently configured for each input channel. The dual voltage measurement, coupled with on-board diagnostic testing, provides comprehensive fault detection and tolerance.

The Module provides on-board Sequence of Events (SOE) reporting with a resolution of 1 ms. A change of state triggers an SOE entry. States are determined by voltage thresholds that can be configured on a per channel basis.

Features:

- 60 duplicated input channels per Module.
- Comprehensive, automatic diagnostics and self-test.
- Selectable line monitoring per channel to detect open circuit and short circuit field wiring faults.
- 2500 V impulse withstand opto/galvanic isolation barrier.
- On-board Sequence of Events (SOE) reporting with 1 ms resolution.
- Configurable 50/60 Hz digital filtering to mitigate field induced noise.
- Module can be hot-replaced on-line using dedicated Companion (adjacent) Slot or SmartSlot (one spare slot for many Modules) configurations. Front Panel Module status LEDs indicate Module health and operational mode (Active, Standby, Educated).
- TÜV Certified IEC 61508 SIL 3.



Page intentionally left blank

PREFACE

In no event will Rockwell Automation be responsible or liable for indirect or consequential damages resulting from the use or application of this equipment. The examples given in this manual are included solely for illustrative purposes. Because of the many variables and requirements related to any particular installation, Rockwell Automation does not assume responsibility or reliability for actual use based on the examples and diagrams.

No patent liability is assumed by Rockwell Automation, with respect to use of information, circuits, equipment, or software described in this manual.

Allen-Bradley, LISTEN. THINK. SOLVE., Rockwell Automation, TechConnect, and Trusted are trademarks of Rockwell Automation, Inc.

Trademarks not belonging to Rockwell Automation are property of their respective companies.

All trademarks are acknowledged.

DISCLAIMER

It is not intended that the information in this publication covers every possible detail about the construction, operation, or maintenance of a control system installation. You should also refer to your own local (or supplied) system safety manual, installation and operator/maintenance manuals.

REVISION AND UPDATING POLICY

This document is based on information available at the time of its publication. The document contents are subject to change from time to time. The latest versions of the manuals are available at the Rockwell Automation Literature Library under "Product Information" information "Critical Process Control & Safety Systems".

TRUSTED RELEASE

This technical manual was updated for **Trusted Release 4.0**.

LATEST PRODUCT INFORMATION

For the latest information about this product review the Product Notifications and Technical Notes issued by technical support. Product Notifications and product support are available at the Rockwell Automation Support Centre at <http://rockwellautomation.custhelp.com>

At the Search Knowledgebase tab select the option "By Product" then scroll down and select the Trusted product.

Some of the Answer ID's in the Knowledge Base require a TechConnectSM Support Contract. For more information about TechConnect Support Contract Access Level and Features please click on the following link:

https://rockwellautomation.custhelp.com/app/answers/detail/a_id/50871

This will get you to the login page where you must enter your login details.

IMPORTANT A login is required to access the link. If you do not have an account then you can create one using the "Sign Up" link at the top right of the web page.

DOCUMENTATION FEEDBACK

Your comments help us to write better user documentation. If you discover an error, or have a suggestion on how to make this publication better, send your comment to our technical support group at <http://rockwellautomation.custhelp.com>

SCOPE

This manual specifies the maintenance requirements and describes the procedures to assist troubleshooting and maintenance of a Trusted system.

WHO SHOULD USE THIS MANUAL

This manual is for plant maintenance personnel who are experienced in the operation and maintenance of electronic equipment and are trained to work with safety systems.

SYMBOLS

In this manual we will use these notices to tell you about safety considerations.



SHOCK HAZARD: Identifies an electrical shock hazard. If a warning label is fitted, it can be on or inside the equipment.



WARNING: Identifies information about practices or circumstances that can cause an explosion in a hazardous environment, which can cause injury or death, property damage or economic loss.



ATTENTION: Identifies information about practices or circumstances that can cause injury or death.



CAUTION: Identifies information about practices or circumstances that can cause property damage or economic loss.



BURN HAZARD: Identifies where a surface can reach dangerous temperatures. If a warning label is fitted, it can be on or inside the equipment.



This symbol identifies items which must be thought about and put in place when designing and assembling a Trusted controller for use in a Safety Instrumented Function (SIF). It appears extensively in the Trusted Safety Manual.

IMPORTANT

Identifies information that is critical for successful application and understanding of the product.

NOTE

Provides key information about the product or service.

TIP

Tips give helpful information about using or setting up the equipment.

WARNINGS AND CAUTIONS

**WARNING: EXPLOSION RISK**

Do not connect or disconnect equipment while the circuit is live or unless the area is known to be free of ignitable concentrations or equivalent

**AVERTISSEMENT - RISQUE D'EXPLOSION**

Ne pas connecter ou déconnecter l'équipement alors qu'il est sous tension, sauf si l'environnement est exempt de concentrations inflammables ou équivalente

**MAINTENANCE**

Maintenance must be carried out only by qualified personnel. Failure to follow these instructions may result in personal injury.

**CAUTION: RADIO FREQUENCY INTERFERENCE**

Most electronic equipment is influenced by Radio Frequency Interference. Caution should be exercised with regard to the use of portable communications equipment around such equipment. Signs should be posted in the vicinity of the equipment cautioning against the use of portable communications equipment.

**CAUTION:**

The module PCBs contain static sensitive components. Static handling precautions must be observed. DO NOT touch exposed connector pins or attempt to dismantle a module.

ISSUE RECORD

Issue	Date	Comments
9	June 05	Reformat
10	Nov 06	Specifications
11	Dec 06	Weights and Dims
12	Nov 07	STATE descriptions
13	Apr 10	Table 12 change
14	Jun 16	Rebranded and reformatted with correction to Relative Humidity Range and Operating Temperature statements in the Specification Section, also any typographical errors
15	March 17	Front Panel image (Figure 4) updated to show new label. In Specifications section, "Field Common Isolation" changed to "Field Common Insulation".
16	Oct 18	Updated Specifications section and main text to a more consistent format. Updated header and footer to display Rockwell Automation publication number. Added trademarks statement.

Page intentionally left blank

Table of Contents

1.	Description	3
1.1.	Field Termination Unit (FTU).....	4
1.2.	Field Interface Unit (FIU).....	5
1.3.	Host Interface Unit (HIU)	5
1.4.	Front Panel Unit (FPU)	6
1.5.	Line Monitoring Thresholds	6
1.6.	Housekeeping.....	8
1.7.	Fault Detection and Testing	8
1.8.	Sequence of Events Characteristics	9
2.	Installation	11
2.1.	Module Insertion/Removal	11
2.2.	Field Cable Selection	11
2.3.	Module Pin-out Connections	12
2.4.	Trusted Module Polarisation/Keying	14
3.	Application	15
3.1.	Module Configuration	15
3.2.	T8402 Complex Equipment Definition	15
3.2.1.	Rack 1: DI	17
3.2.2.	Rack 2: STATE	17
3.2.3.	Rack 3: AI	18
3.2.4.	Rack 4: SPARE	19
3.2.5.	Rack 5: LINE_FLT	19
3.2.6.	Rack 6: DISCREP	20
3.2.7.	Rack 7: HKEEPING	20
3.2.8.	Rack 8: Information	22
3.3.	Sequence of Events Configuration	24
3.4.	System.INI File Configuration.....	24
4.	Operation	25
4.1.	Front Panel	25
4.2.	Module Status LEDs.....	26
5.	Fault Finding and Maintenance.....	28
5.1.	Fault Reporting.....	28
5.2.	Field Wiring Faults.....	28
5.3.	Module Faults	28

5.4.	Companion Slot.....	29
5.5.	SmartSlot.....	29
5.6.	Cold Start.....	29
5.7.	Input Channel Calibration Check.....	30
5.8.	Transfer between Active and Standby Modules.....	30
6.	Specifications.....	32

1. Description

The Trusted Dual 24 Vdc Digital Input Module is a member of the Trusted range of Input/Output (I/O) Modules. All Trusted I/O Modules share common functionality and form. At the most general level, all I/O Modules interface to the Inter-Module Bus (IMB) which provides power and allows communication with the Trusted TMR Processor. In addition, all Modules have a field interface that is used to connect to Module specific signals in the field.

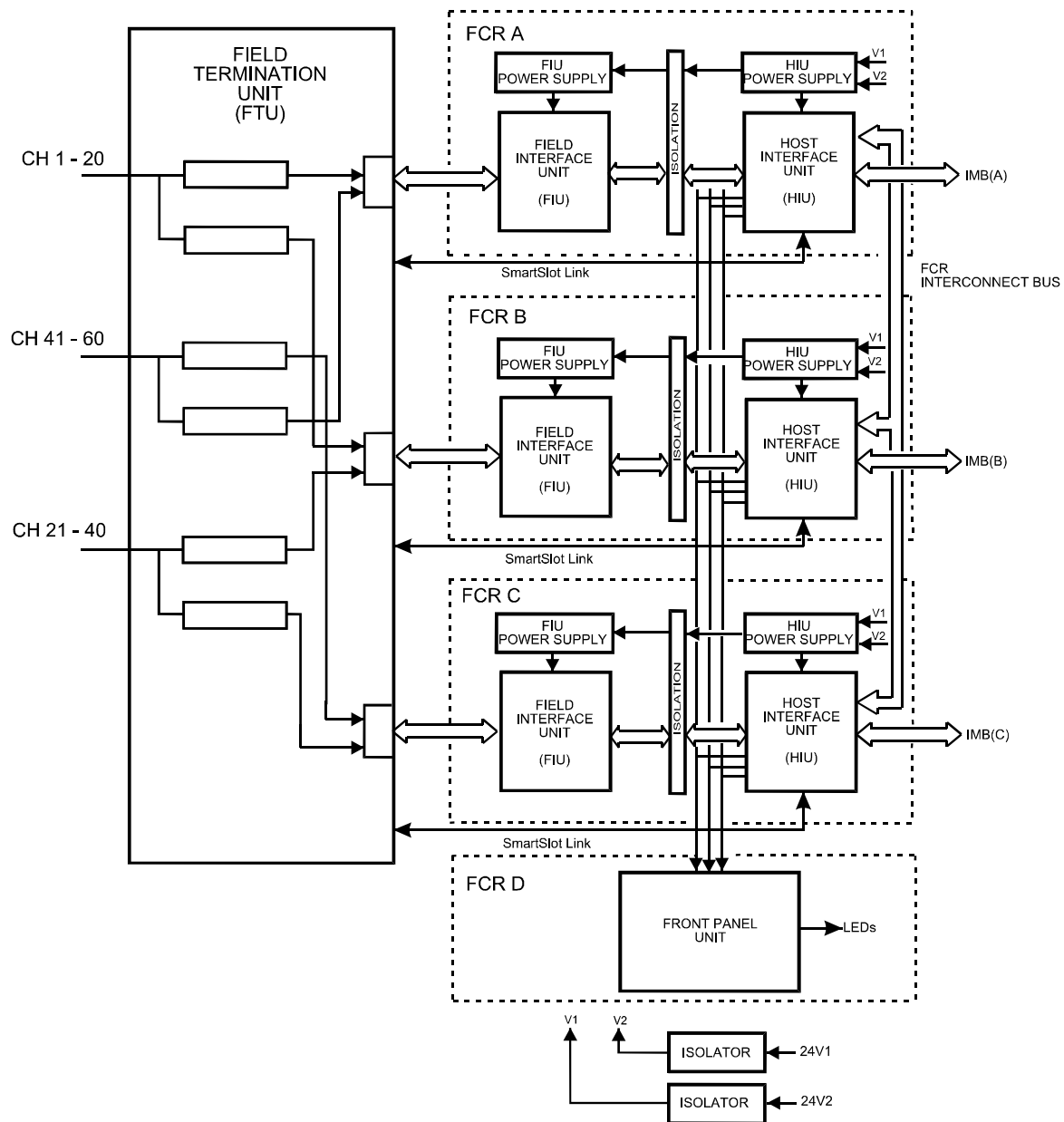

Figure 1 Module Architecture

All Trusted I/O Modules comprise four sections: Host Interface Unit (HIU), the Field Interface Unit (FIU), the Field Termination Unit (FTU) and the Front Panel Unit (or FPU).

Figure 2 shows a simplified functional block diagram of the Trusted Dual 24 Vdc Digital Input Module.

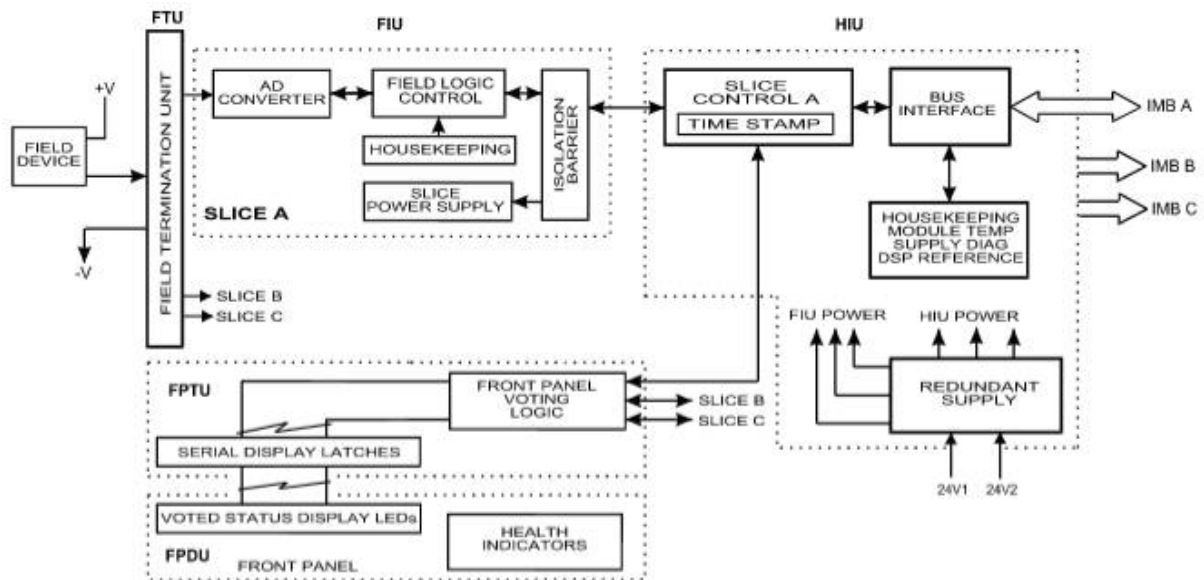

Figure 2 Functional Block Diagram

1.1. Field Termination Unit (FTU)

The Field Termination Unit (FTU) is the section of the I/O Module that connects the appropriate two FIUs to a single field device as shown in Figure 1. The FTU primarily contains passive components (scaling resistors) necessary for front-end signal conditioning, field signal over-voltage protection, and EMI/RFI filtering. When installed in a Trusted Controller or Expander Chassis, the FTU field connector interconnects to the I/O cable assembly attached at the rear of the Chassis

The SmartSlot link is passed from the HIU to the field connections via the FTU. These signals go directly to the I/O cable assembly and maintain isolation from the I/O signals on the FTU. The SmartSlot link is the intelligent connection between Active and Standby Modules for coordination during Module replacement.

1.2. Field Interface Unit (FIU)

The Field Interface Unit (FIU) is the section of the Module that contains the specific circuits necessary to interface to the particular types of field I/O signals. Each Module has three FIUs, one per slice. For the Dual 24 Vdc Digital Input Module, the FIU contains an individual analogue to digital (A/D) converter for each of the 60 field inputs.

The FIU receives isolated power from the HIU for logic. The FIU provides additional power conditioning for the operational voltages required by the FIU circuitry. An isolated serial link connects each FIU to one of the HIU slices.

The FIU also measures a range of on-board “housekeeping” signals that assist in monitoring the performance and operating conditions of the Module. These signals include power supply voltages, current consumption, on-board reference voltages and board temperature.

1.3. Host Interface Unit (HIU)

The HIU is the point of access to the Inter-Module Bus (IMB) for the Module. It also provides power distribution and local programmable processing power. The HIU is the only section of the I/O Module to directly connect to the IMB Backplane. The HIU is common to most Trusted I/O types and has type dependent and product range common functions. Each HIU contains three independent slices, commonly referred to as A, B, and C.

All interconnections between the three slices incorporate isolation to prevent any fault interaction between the slices. Each slice is considered a Fault Containment Region (FCR), as a fault on one slice has no effect on the operation of the other slices.

The HIU provides the following services common to the Modules in the family:

- High Speed Fault Tolerant Communications with the TMR Processor via the IMB Interface.
- FCR Interconnect Bus between slices to vote incoming IMB data and distribute outgoing I/O Module data to the IMB.
- Galvanically isolated serial data interface to the FIU slices.
- Redundant power sharing of dual 24 Vdc chassis supply voltage and power regulation for logic power to HIU circuitry.
- Magnetically isolated power to the FIU slices.
- Serial data interface to the FPU for Module status LEDs.
- SmartSlot link between Active and Standby Modules for co-ordination during Module replacement.
- Digital Signal Processing to perform local data reduction and self-diagnostics.

- Local memory resources for storing Module operation, configuration, and field I/O data.
- On-board housekeeping, which monitors reference voltages, current consumption and board temperature.

1.4. Front Panel Unit (FPU)

The Front Panel Unit (FPU) comprises a Front Panel Termination Unit (FPTU) and a Front Panel Display Unit (FPDU). The overall FPU contains the necessary connectors, switches, logic, and LED indicators for the Front Panel. For every type of Trusted I/O Module, the FPU contains the Slice Healthy, Active/Standby and Educated indicators (LEDs), and the Module removal switches. Serial data interfaces connect the FPU to each of the HIU slices to control the LED status indicators and monitor the Module removal switches.

1.5. Line Monitoring Thresholds

The Module determines the contact state and line fault status by comparing the input voltage level to four user programmed thresholds and two fixed (minimum and maximum) thresholds. A “Contact Indeterminate” region is defined between the contact Closed and Open states to account for marginal faults in the external wiring or in the FIU. Hysteresis is provided on the thresholds by upscale and downscale values, corresponding to the thresholds for increasing and decreasing values respectively.



Typical voltage threshold values			Input Channel State	DI Status	Line Fault Status
		Over-range	6	0	1
Tmax	32.0				
		Short Circuit	5		
T8	20.0		4 or 5 (see Note)	0/1	0/1
T7	19.5				
		Contact Closed	4	'1'	0
T6	16.0		3 or 4	0/1	0/1
T5	15.5				
		Contact Indeterminate	3	0	1
T4	8.5		2 or 3		0
T3	8.0				
		Contact Open	2		
T2	4.5		1 or 2		0/1
T1	4.0				
		Open Circuit	1		1
Tmin	0.0				
		Under-range	0		

Table 1 Example Threshold Data (24 Vdc)

Note: The channel state value returned is dependent on the previous state value. If the input level is increasing then the lower state value will be returned. If the input level is decreasing the higher state value will be returned.

When a Module is inserted into the Standby slot in a line-monitored application, then the field terminations for all the input channels are paralleled, resulting in a drop in the input voltages for the Active Module.

The threshold values are recalculated and configured so that this does not result in the inadvertent reporting of the Contact-Open or Contact-Indeterminate states.

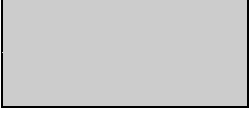
When the Module is used in the purely digital input mode, each input channel is biased by means of a 5 k Ω (typical for 24Vdc digital inputs) termination resistor to the 0 V reference of the Module input circuitry. This resistor is located on the Trusted Field Termination Assembly, 24 Vdc Digital Input 60 Channels T8802. In the absence of any line fault, the resistors used for line monitoring purposes form a voltage divider with the termination resistor in the Module. Typically, the values are chosen so that the open contact voltage at the input terminal is about $\frac{1}{3}$ of the field supply; with the user contact closed the voltage is about $\frac{2}{3}$ of the field supply.

Default threshold values used for non-line monitored inputs are as follows (in raw units):

Default = -2403, -1971, 3046, 3072, 7168, 8192, 14848, 15872

1.6. Housekeeping

The Input Module automatically performs local measurements of several on-board signals that can be used for detailed fault finding and verification of Module operating characteristics. Measurements are made within each slice's HIU and FIU.

1.7. Fault Detection and Testing

Extensive diagnostics provide the automatic detection of Module faults. The TMR architecture of the Output Module and the diagnostics performed verify the validity of all critical circuits. Using the TMR architecture provides a Fault Tolerant method to withstand the first fault occurrence on the Module and continue normal output controls without interruption in the system or process. Faults are reported to the user through the Healthy status indicators on the Front Panel of the Module and through the information reported to the TMR Processor. Under normal operations all three Healthy indicators are green. When a fault occurs, one of the Healthy indicators will be flashing red. It is recommended that this condition is investigated and if the cause is within the Module, it should be replaced.

Module replacement activities depend on the type of spare Module configuration chosen when the system was configured and installed. The Module may be configured with a dedicated Companion Slot or with a SmartSlot for a spare replacement Module.

From the IMB to the field connector, the Input Module contains extensive fault detection and integrity testing. As an input device, all testing is performed in a non-interfering mode. Data input from the IMB is stored in redundant error-correcting RAM on each slice portion of the HIU. Received data is voted on by each slice. All data transmissions include a confirmation response from the receiver.

Periodically, the TMR Processor commands the on-board Digital Signal Processors (DSPs) to perform a Safety Layer Test (SLT). The SLT results in the DSP verifying with the TMR Processor its ability to process data with integrity. In addition, the DSP uses Cyclical Redundancy Checks (CRC) to verify the variables and configuration stored in Flash memory.

Between the HIU and FIU, there are a series of galvanically isolated links for data and power. The data link is synchronised and monitored for variance. Both the FIU and HIU have on-board temperature sensors to characterise temperature related problems.

The power supplies for both the HIU and FIU boards are redundant, fully instrumented and testable. Together, these assemblies form a Power Integrity Sub-system.

The Module field input is connected to a single bit analogue to digital converter (ADC) known as the $\Sigma\Delta$ input circuit. These circuits, one per channel on each slice, produce a digital output which naturally transitions between on and off. Any failure in the circuit causes the output to saturate to stuck-on or stuck-off which is automatically detected. As the conversion process is dynamic and not gated like traditional ADCs, failures are rapidly diagnosed and located.

By using the $\Sigma\Delta$ circuit, the analogue path in the Module is short and does not involve many components. This results in analogue failures being contained to a single channel on a single slice instead of causing a group of eight or more inputs to fail.

1.8. Sequence of Events Characteristics

The input Module automatically measures the field-input voltage, compares the value to the configurable thresholds, and determines the state of the field input. An event occurs when the input transitions from one state to another. When an input changes state, the on board real-time clock value is recorded. When the TMR Processor next reads data from the input Module, the input state and real-time clock values are retrieved. The TMR Processor uses this data to log the input state change into the system Sequence of Events (SOE) log. The user may configure each input to be included in the system SOE log. Full details of SOE are contained in Trusted Sequence of Events and Process Historian Package, publication [ICSTT-RM243](#) (PD-T8013).

Page intentionally left blank

2. Installation

2.1. Module Insertion/Removal

**CAUTION:**

The Module contains static sensitive parts. Static handling precautions must be observed. Specifically verify that exposed connector pins are not touched. Under no circumstances should the Module housing be removed.

Before installation, visually inspect the Module for damage. Verify that the Module housing appears undamaged and inspect the I/O connector at the back of the Module for bent pins. If the Module appears damaged or any pins are bent, do not install the Module. Do not try to straighten bent pins. Return the Module for replacement.

Verify that the Module is of the correct type.

Record the Module type, revision and serial number of the Module before installation.

To install the Module:

1. Verify that the field cable assembly is installed and correctly located.
2. If I/O module keys are used, verify that all keys are installed in the correct positions and properly seated in their slots.
3. Release the ejector tabs on the Module using the release key. Verify that the ejector tabs are fully open.
4. Holding the ejectors, carefully insert the Module into the intended slot.
5. Push the Module fully home by pressing on the top and bottom of the Module fascia.
6. Close the Module ejectors, ensuring that they click into their locked position.

The Module should mount into the chassis with a minimum of resistance. If the Module does not mount easily, do not force it. Remove the Module and check it for bent or damaged pins. If the pins have not been damaged, try reinstalling the Module.

2.2. Field Cable Selection

I/O cables suitable for use with the Trusted Dual 24 Vdc Digital Input Module are detailed in the following Product Descriptions.

1. Trusted I/O SmartSlot Cables 60-Channel, publication [ICSTT-RM314](#) (PD-TC600)
2. Trusted I/O Companion Slot Cables 60-Channel, publication [ICSTT-RM315](#) (PD-TC700)

The Product Descriptions detailed above also detail the types of Field Termination Assembly (FTA) or Versatile Field Termination Assembly (VFTA) which may be used with this type of Module.

2.3. Module Pin-out Connections

	C	B	A
1	SmartSlot Link C	SmartSlot Link B	SmartSlot Link A
2	N/C	N/C	N/C
3	Chan 28 BC	Chan 14 AB	Chan 0 ABC
4	Chan 48 A	Chan 54 C	Chan 0 ABC
5	Chan 29 BC	Chan 15 AB	Chan 1 AB
6	Chan 49 A	Chan 55 C	Chan 41 C
7	Chan 30 BC	Chan 16 AB	Chan 2 AB
8	Chan 50 A	Chan 56 C	Chan 42 C
9	0V	0V	0V
10	Chan 31 BC	Chan 17 AB	Chan 3 AB
11	Chan 51 A	Chan 57 C	Chan 43 C
12	Chan 32 BC	Chan 18 AB	Chan 4 AB
13	Chan 52 A	Chan 58 C	Chan 44 C
14	Chan 33 BC	Chan 19 AB	Chan 5 AB
15	Chan 53 A	Chan 59 C	Chan 45 C
16	Chan 34 BC	Chan 20 AB	Chan 6 AB
17	Chan 54 A	Chan 60 C	Chan 46 C
18	Chan 35 BC	Chan 21 BC	Chan 7 AB
19	Chan 55 A	Chan 41 A	Chan 47 C

	C	B	A
20	0V	0V	0V
21	Chan 36 BC	Chan 22 BC	Chan 8 AB
22	Chan 56 A	Chan 42 A	Chan 48 C
23	Chan 37 BC	Chan 23 BC	Chan 9 AB
24	Chan 57 A	Chan 43 A	Chan 49 C
25	Chan 38 BC	Chan 24 BC	Chan 10 AB
26	Chan 58 A	Chan 44 A	Chan 50 C
27	Chan 39 BC	Chan 25 BC	Chan 11 AB
28	Chan 59 A	Chan 45 A	Chan 51 C
29	Chan 40 BC	Chan 26 BC	Chan 12 AB
30	Chan 60	Chan 46 A	Chan 52 C
31	Chan 61 ABC	Chan 27 BC	Chan 13 AB
32	Chan 61 ABC	Chan 47 A	Chan 53 C

Table 2 Field Connector Pin-out

Note: The letters appended to the channel numbers indicate the destination slice on the Module for the incoming signal from the field.

2.4. Trusted Module Polarisation/Keying

All Trusted Modules have been keyed to prevent insertion into the wrong position within a Chassis. The polarisation comprises two parts; the Module, and the associated field cable.

Each Module type has been keyed during manufacture. The organisation responsible for the integration of the Trusted System must key the cable by removing the keying pieces from the cable so that they correspond with the bungs fitted to the associated Module prior to fitting.

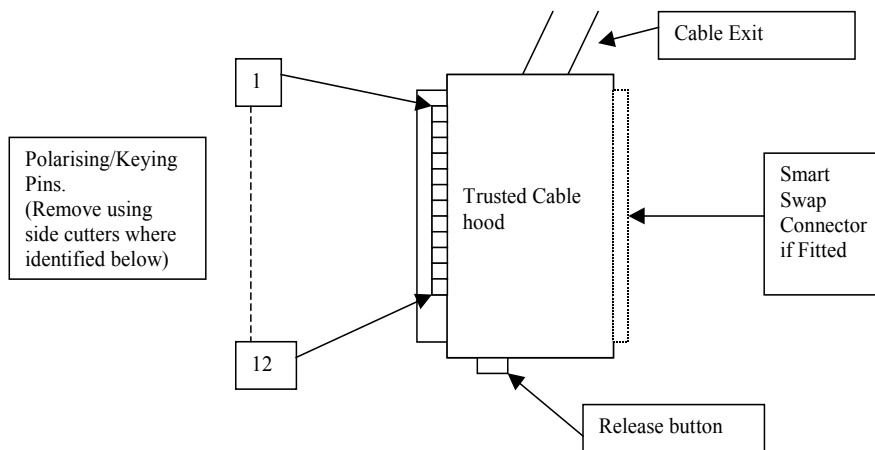

Figure 3 Module Polarisation

For Cables with Companion Slot installations both keying strips must be polarised.

For this Module (T8402) remove keying pins 1, 3 and 4.

3. Application

3.1. Module Configuration

There is no configuration required to the physical Input Module. All configurable characteristics of the Module are performed using tools on the Engineering Workstation (EWS) and become part of the application or System.INI file that is loaded into the TMR Processor. The TMR Processor automatically configures the Input Module after applications are downloaded and during Active/Standby changeover.

The IEC 61131 TOOLSET provides the main interface to configure the Input Module. Details of the configuration tools and configuration sequence are provided in Trusted Toolset Suite, publication [ICSTT-RM249](#) (PD-T8082). There are three procedures necessary to configure the Input Module. These are:

1. Define the necessary I/O variables for the field input data and Module status data using the Dictionary Editor of the IEC 61131 TOOLSET.
2. Create an I/O Module definition in the I/O Connection Editor for each I/O Module. The I/O Module definition defines physical information, e.g. Chassis and Slot location, and allows variables to be connected to the I/O channels of the Module.
3. Using the Trusted System Configuration Manager, define custom LED indicator modes, per-channel threshold levels and noise filtering, and other Module settings.

3.2. T8402 Complex Equipment Definition

The T8402 I/O Complex Equipment Definition includes 8 I/O boards, referenced numerically by Rack number:

Rack	I/O Board	Description	Data Type	Direction	No. of Channels
1	DI	OEM Parameters	-	-	-
		Field Input Status	Boolean	In	60
2	STATE	Field Input State	Integer	In	60
3	AI	Input voltage	Integer	In	60
4	SPARE	Not Implemented	Integer	In	16
5	LINE_FLT	Line Fault Status	Boolean	In	60

Rack	I/O Board	Description	Data Type	Direction	No. of Channels
6	DISCREP	Channel Discrepancy	Integer	In	4
7	HKEEPING	Housekeeping Registers	Integer	In	51
8	INFO	I/O Module Information	Integer	In	11

Table 3 Complex Equipment Definition

There are two OEM parameters included in the first rack (DI Board). These OEM parameters define the primary Module position; declaring the Module's chassis and slot location. There is no need to define the secondary Module position within the IEC 61131 TOOLSET. Where systems may be required to start-up with a Module in the secondary position as the Active Module, e.g. primary Module is not installed when application is started, the secondary Module's position should be declared in the Module definition of the System Configuration Manager.

OEM Parameter	Description	Notes
TICS_CHASSIS	The number of the Trusted Chassis where the primary I/O Module is installed	The Trusted Controller Chassis is 1, and Trusted Expander Chassis are 2 to 15
TICS_SLOT	The slot number in the Chassis where the primary I/O Module is installed	The I/O Module slots in the Trusted Controller chassis are numbered from 1 to 8. The I/O Module slots in the Trusted Expander Chassis are numbered from 1 to 12

Table 4 OEM Parameters

3.2.1. Rack 1: DI

This board provides the logical input state for each of the field inputs.

Channel	Description
1	Field input channel 1 logical state
2	Field input channel 2 logical state
60	Field input channel 60 logical state

Table 5 Rack 1: DI descriptions

The input state is reported as true (logic '1') for a closed contact input, and false (logic '0') for an open contact input. The logic state is 1oo2D voted from the Module.

3.2.2. Rack 2: STATE

This board provides the majority voted numerical input state. This input channel state indicates the threshold band within which the input voltage lies.

Channel	Description
1	Field input channel 1 state
2	Field input channel 2 state
60	Field input channel 60 state

Table 6 Rack 2: STATE Descriptions

Value	Description
7	Unknown
6	Over-range
5	Short circuit
4	Closed contact
3	Indeterminate

Value	Description
2	Open contact
1	Open circuit
0	Under-range

Table 7 Rack 2: STATE Output Descriptions

The input channel has a value 7 (Unknown) when:

1. The input channel cannot be correctly measured by two or more slices of the TMR Input Module.
2. The TMR Processor detects a 1oo2D channel discrepancy between the appropriate slices of the dual Input Module.
3. The Module is simulated (not installed or the TMR Processor cannot communicate with 1oo2D slices of the Module).

3.2.3. Rack 3: AI

The AI board returns the field loop voltage at the input.

Channel	Description
1	Field input channel 1 voltage
2	Field input channel 2 voltage
60	Field input channel 60 voltage

Table 8 Rack 3: Channel Field Voltage

The voltage is the lower value taken from the two slices. The voltage level is reported as an integer, with the units being $\frac{1}{512}$ V. This may be used directly, scaled arithmetically or scaled using the IEC 61131 TOOLSET conversion tables.

When used directly the value may be considered as a signed, fixed-point binary value, i.e.:

Bit																
15	14	13	12	11	10	9		8	7	6	5	4	3	2	1	0
Sign	Integer							Fractional								

Table 9 Rack 3: Channel Field Voltage Bit Definitions

To scale the value arithmetically, simply divide the input value by 512 to return the voltage as either a REAL or INTEGER as required.

The IEC 61131 TOOLSET conversion tables may be used to convert the input value to engineering units, in this case voltage. The full scale range for this number format is decimal ± 64 , corresponding to physical range -32768 to $+32767$. Other units may be chosen depending on the numeric resolution and span of the desired result.

When the TMR Processor detects a 1oo2D channel fault or discrepancy, or if the Input Module is simulated, the input voltage numeric value is reported as -2048 .

3.2.4. Rack 4: SPARE

This rack is reserved for future used and is included to promote consistency with other Trusted I/O Modules.

3.2.5. Rack 5: LINE_FLT

Channel	Description
1	Field input channel 1 line fault
2	Field input channel 2 line fault
60	Field input channel 60 line fault

Table 10 Rack 5: LINE_FLT

The line fault input is reported as true (logic '1') for a line fault condition (open circuit, indeterminate, or short circuit condition). The logic state is the majority voted value.

When the TMR Processor detects a 1oo2D channel fault or discrepancy, or if the input Module is simulated, the line fault input is set to True.

3.2.6. Rack 6: DISCREP

Channel	Description
1	Discrepancy status inputs 1 to 16 (input 1 is LSB, bit 0)
2	Discrepancy status inputs 17 to 32 (input 17 is LSB, bit 0)
3	Discrepancy status inputs 33 to 48 (input 33 is LSB, bit 0)
4	Discrepancy status inputs 49 to 60 (input 49 is LSB, bit 0, bits 12 – 15 are set to zero)

Table 11 Rack 6: DISCREP bit descriptions

Each of the integers reports the discrepancy status of 16 input channels. The corresponding bit within the integer is set to '1' when a discrepancy condition is detected on that input channel's input state (rack 2). For example, if Slice B of the Input Module reports the state of channel 4 as state 5, while Slice A reports channel 4 as state 2, then Slice B has a channel discrepancy for channel 4. In this case, bit 3 of channel 1 on the Discrepancy board would be set to '1'.

3.2.7. Rack 7: HKEEPING

Channel	Description				
	FCR		Units (Full Scale Range)		
1	A	24V2 Input Voltage	-32768	32767	mV
2	B				
3	C				
4	A	Internal supply voltage (post regulator)	-32768	32767	mV
5	B				
6	C				
7	A	Internal supply current (post regulator)	0	65535	mA
8	B				
9	C				
10	A	Input voltage (post isolation)	-32768	32767	mV
11	B				
12	C				
13	A	24V1 Input Voltage	-32768	32767	mV
14	B				
15	C				

Channel	Description				
	FCR		Units (Full Scale Range)		
16	A	HIU Board Temperature (Note: Temperature, °C = input value / 256)	-32768	32767	-
17	B				
18	C				
19	A	Front Panel Load Current	0	65535	mA
20	B				
21	C				
22	A	SmartSlot Link Voltage	-32768	32767	mV
23	B				
24	C				
25	A	Reserved for FIU condensation sensor	0	0	-
26	B				
27	C				
28	A	FIU Internal Supply Voltage	-32768	32767	mV
29	B				
30	C				
31	A	FIU Internal Supply Current	0	65535	mA
32	B				
33	C				
34	A	FIU Unregulated input voltage	-32768	32767	mV
35	B				
36	C				
37	A	FIU Board Temperature (Note: Temperature, °C = input value / 256)	-32768	32767	-
38	B				
39	C				
40	A	FIU Reference Voltage, DAC_X1	-32768	32767	mV
50	B				
42	C				
43	A	FIU Reference Voltage, DAC_X2	-32768	32767	mV
44	B				
45	C				
46	A	FIU Reference Voltage, DAC_X3	-32768	32767	mV
47	B				

Channel	Description				
	FCR				Units (Full Scale Range)
48	C				
49	A	Diagnostic error code			
50	B				
51	C				

Table 12 Rack 7: Housekeeping Descriptions

Each input within the housekeeping rack is reported as an integer. In general, the application engineer will not normally require these inputs. They are provided to aid fault finding and diagnosis and are often used for reporting and display purposes. If a slice is Fatal, then all reported housekeeping inputs are set to zero.

3.2.8. Rack 8: Information

Channel	Description
1	Active Module chassis number
2	Active Module slot number
3	Active Module healthy
4	Active Module state
5	Standby Module chassis number
6	Standby Module slot number
7	Standby Module healthy
8	Standby Module state
9	Fault Containment Region (FCR) status
10	Primary Module is active
11	Active Module is simulated

Table 13 Rack 8: INFO Descriptions

The Active Module chassis and slot numbers indicate the position of the currently Active Module. These values will change to match the primary or secondary Module position, depending on their active status, i.e. active/standby changeover will “swap” the values for

the Active Module chassis and slot number channels with those in the Standby Module chassis and slot number channels.

The Active and Standby Module healthy channel is returned as an integer. A value of 0 indicates that a fault has been detected; a value of '1' indicates that the Module is healthy.

The Active and Standby Module state is an integer indicating the current operating mode of the associated Module. The value indicates the current internal operating mode of the Module.

Value	Module State
5	Shutdown
4	Maintain
3	Active
2	Standby
1	Configuration
0	Unknown, no Module present, or Module is Fatal

Table 14 Rack 8: INFO Bit Descriptions

The FCR status channel reports the fault status of each slice of the Active and Standby Modules. The value is bit-packed as shown below. The least significant byte is used with the most significant 8-bits set to zero:

Bit							
7	6	5	4	3	2	1	0
Standby Module				Active Module			
Ejectors open	FCR C Healthy	FCR B Healthy	FCR A Healthy	Ejectors open	FCR C Healthy	FCR B Healthy	FCR A Healthy

Table 15 Rack 8: FCR bit Description

The 'Primary Module is active' channel is set to non-zero if the primary Module is the current Active Module, i.e. the Active Module is in the chassis and slot numbers defined within the OEM parameters.

The 'Active Module is simulated' channel is set to '1' if the Active Module is being simulated, this will only be set if the Module is not present or non-operational and the simulation enable has been set within the Module's configuration in the System.INI file.

3.3. Sequence of Events Configuration

Each Boolean Input Variable can be configured for automatic Sequence of Events (SOE) logging. This applies to the Input Status and Line Fault Status variables. A Boolean variable is configured for SOE during the variable definition in the Data Dictionary Editor. To select SOE, press the Extended Button in the Boolean Variable Definition Dialog Box to open the Extended Definition Dialog. Then check the box for Sequence of Events to enable the variable for automatic SOE logging.

During operation, the Input Module automatically reports time-stamped change of state information for the input data. The TMR Processor automatically logs change of state for configured SOE variables into the system SOE Log. The SOE Log can be monitored and retrieved using the SOE and Process Historian Package running on the EWS. This software package is described in Trusted Sequence of Events and Process Historian Package, publication [ICSTT-RM243](#) (PD-T8013).

3.4. System.INI File Configuration

There are many operating characteristics of the Input Module that can be customised for a particular application. The System Configuration Manager is a tool that allows the user to configure the specific operating characteristics for each Module. Descriptions of the items that may be configured for the Trusted Dual 24 Vdc Digital Input Module T8402 are contained in Trusted Toolset Suite, publication [ICSTT-RM249](#) (PD-T8082).

Certain characteristics apply to the entire Module and are considered Module Configurable Items. Other characteristics apply to individual input channels and are considered Channel Configurable Items. There are specific default settings for each of the configurable items. If the default settings are appropriate for a given application, customization of the Module definition in the System Configuration Manager is not required.

4. Operation

4.1. Front Panel

Status LEDs on the front of the Module provide visual indications of the Module's operational status. Each LED is a tri-colour LED of which for normal operation, only two colours are used; red and green. Located at the top and bottom of each Module is an ejector lever that is used to remove the Module from the chassis. Limit switches detect the open/closed position of the ejector levers. The ejector levers are normally latched closed when the Module is firmly seated into the Controller or Expander Chassis.



Figure 4 Module Front Panel

4.2. Module Status LEDs

There are six Module status LEDs on the Module front panel; three Healthy, one Active, one Standby, and one Educated. The Healthy indicators are controlled directly by each Module slice. The Active, Standby, and Educated indicators are controlled by the FPU. The FPU receives data from each of the Module slices. It performs a 2oo3 vote on each data bit from the slices and sets the indicators accordingly.

The Module status LED states and their meanings are described as follows:

LED	STATE	DESCRIPTION
Healthy	Off	No power applied to the Module.
	Amber	Slice is in the start-up state (momentary after installation or power-up).
	Green	Slice is healthy.
	Red – flashing	Fault present on the associated slice but the slice is still operational, or one 24 V feed to the chassis has failed.
	Red (momentary)	On installation – power applied to the associated slice.
Active	Red	The associated slice is in the fatal state. A critical fault has been detected and the slice disabled.
	Off	Module is not in the Active state.
	Green	Module is in the Active (or Maintain) state.
	Red – flashing	Module is in the shutdown state if the Standby LED is off.
Standby	Red – flashing	Module is in the fatal state if the Standby LED is also flashing.
	Off	Module is not in the Standby state.
	Green	Module is in the Standby state.
	Red – flashing	Module is in the fatal state. The Active LED will also be flashing red.

LED	STATE	DESCRIPTION
Educated	Off	Module is not educated.
	Green	Module is educated.
	Green – flashing	Module is recognised by the Processor but education is not complete.
	Amber - Flashing	Active/Standby changeover in progress.

Table 16 Module Status LEDs

5. Fault Finding and Maintenance

5.1. Fault Reporting

Input Module faults are reported to the user through visual indicators (LEDs) on the Front Panel of the Module. Faults are also reported via status variables which may be automatically monitored in the application programs, and external system communications interfaces. There are generally two types of faults that must be remedied by the user; external wiring and Module faults. External wiring faults require corrective action in the field to repair the fault condition. Module faults require replacement of the Input Module.

5.2. Field Wiring Faults

The input circuits of the Module may be used to detect field wiring faults in addition to alarm states. To achieve this, line monitoring components must be fitted to the field device.

By comparing the input signal from the field with pre-configured alarm thresholds, the Module can automatically detect field wiring faults. When a field signal fails open or short-circuit, or to an intermediate value, the input state will be reported and the line fault status for that channel will be set to '1'. All other input channels will be unaffected, except in the case of common cause wiring faults in the field.

Once the field wiring fault has been identified and corrected, the input status will display the normal on/off status of the field device and field wiring.

5.3. Module Faults

Extensive diagnostics provide the automatic detection of Module faults. The 1oo2D Dual architecture of the Input Module and the diagnostics performed verify the validity of all critical circuits. Using the 1oo2D Dual architecture provides a fault tolerant method to withstand the first fault occurrence on the Module and continue normal input measurements without interruption in the system or process. Faults are reported to the user through the Healthy status LEDs on the Front Panel of the Module and through the INFO and HKEEPING variables. Under normal operations all three Healthy LEDs are green. When a fault occurs, one of the Healthy LEDs will flash red. It is recommended that this condition is investigated and if the cause is within the Module, it should be replaced.

Module replacement activities depend on the type of spare Module configuration chosen when the system was configured and installed. The Module may be configured with a dedicated Companion Slot or with a SmartSlot for a spare replacement module.

5.4. Companion Slot

For a Companion Slot configuration, two adjacent slots in a Trusted Chassis are configured for the same Input Module function. One slot is the primary slot and the other a unique secondary (or spare) slot. The two slots are joined at the rear of the Trusted Chassis with a double-wide I/O Interface Cable that connects both slots to common field wiring terminations. During normal operations, the primary slot contains the Active Module as indicated by the Active indicator on the Front Panel of the Module. The secondary slot is available for a spare Module that will normally be the Standby Module as indicated by the Standby indicator on the Front Panel of the Module.

Depending on the installation, a hot-spare Module may already be installed, or a Module blank will be installed in the standby slot. If a hot-spare Module is already installed, transfer to the Standby Module occurs automatically when a Module fault is detected in the Active Module. If a hot spare is not installed, the system continues operating from the Active Module until a spare Module is installed.

5.5. SmartSlot

For a SmartSlot configuration, the secondary slot is not unique to each primary slot. Instead, a single secondary slot is shared among many primary slots. This technique provides the highest density of Modules to be fitted in a given physical space. At the rear of the Trusted Chassis, a single-wide I/O Cable connects the secondary slot directly to the I/O Cable connected to the failed primary Module. With a spare Module installed in the SmartSlot and the SmartSlot I/O Cable connected to the failed primary Module, the SmartSlot can be used to replace the failed primary Module.

Input Module Smart Slot jumper cable TC-306-02

SmartSlot between Chassis can be performed if the Chassis are version 2 (or higher). These have the connector fitted to enable connection of a TC-006, which verifies that the 0 Volt of each chassis is at the same potential.

5.6. Cold Start

If an I/O Module has shut down (due, for example, to two existing faults), the three Healthy LEDs will be red, the Active and Standby LEDs will be flashing red and the Educated LED will be flashing amber. The I/O functions provided by this Module will have been lost if a hot swap partner has not taken over control. The Module can only be restarted by removing it from its slot and re-inserting it.

If an I/O Module is inserted into a functional system slot which previously had no Active Module (e.g. removing and reinserting as above), then the Processor will educate the Module once it has booted. Once educated, the Educated LED will be steady green and the Active LED will be red flashing.

Input Modules will now be reading and reporting their inputs. Output Modules have not yet energised their outputs. To activate outputs and to set the Module's Active LED and the Processor's System Healthy LED steady green, press the Processor Reset pushbutton.

5.7. Input Channel Calibration Check

It is recommended that a check is carried out at 2 yearly intervals on the input channel calibration. This check will detect long term drift and any inaccuracy as a result. Refer to T8094 Trusted Safety Manual §Appendix F.

5.8. Transfer between Active and Standby Modules

The TMR Processor is responsible for managing a pair of I/O Modules through an Active/Standby changeover. The following rules apply to Active/Standby changeovers, though the TMR Processor and not the I/O Module enforces them:

- The user must define the primary, and optionally the secondary, I/O Module location for each I/O Module pair. Each primary Module location must be unique and is defined as part of the complex equipment definition within the IEC 61131 TOOLSET. Secondary Module locations can be unique or shared between multiple secondary Modules and are defined within the Module's section within the System.INI file. The system will automatically determine the secondary Module position if the primary Module is installed and is operable.
- On initial start-up, if the primary Module is installed, it will become the Active Module by default. If the secondary Module has been defined within the System.INI file and no primary Module is present, and if the secondary Module location is unique, the secondary Module will become the Active Module by default. If the secondary Module is installed with no primary Module present, and the secondary Module location is not unique (as in a SmartSlot configuration), then NO Module for that Module pair will become Active.
- In order for a Module to become the Active Module, the TMR Processor will verify that the Module is the correct I/O Module type and that both Module Removal switches are closed. At this point the I/O Module is configured and eventually placed in the Active state.
- A Module in the Active state should never be removed.
- When a fault occurs on the Active Module, the TMR Processor will be informed. Once it becomes aware of the fault, the TMR Processor will attempt an Active/Standby changeover.

- An Active/Standby changeover starts with the TMR Processor checking to see if a Standby I/O Module is installed. If no Standby I/O Module is available, the TMR Processor will continue to utilise the Active Module and will continue to check for an available Standby I/O Module. Once a Standby Module is found, the TMR Processor will verify that the I/O Module is of the correct type, that both Module Removal switches are closed, and that the I/O Module is a part of the correct Module pair by using the SmartSlot link. At this point, the TMR Processor will configure the Standby I/O Module with the same configuration information as the currently Active I/O Module and place the Standby I/O Module into the Standby state. The Active Module is then placed in the Maintain state (which suspends field loop testing), and any Module specific changeover data is transferred. The Educated light flashes amber before the Active/Standby changeover takes place, to indicate transfer of dynamic change over data (COD). The previous Standby Module then becomes the Active Module and the original Module becomes Standby. If the currently Active Module does not successfully complete the self-tests, the TMR Processor will revert it to the Standby state, and the Module in the Maintain state will revert back to the Active state.

When both Module Removal switches are opened on an Active Module, regardless of the Module fault status, the TMR Processor will treat it as a request to perform an Active/Standby changeover

Under normal conditions, an Active/Standby changeover will only occur if the new Active Module is fault free. Under some circumstances, it is desirable to be able to force a changeover to a known faulted Module. This can be accomplished by opening the Module Removal switches on the currently Active Module and pressing the pushbutton reset on the TMR Processor. This will force the changeover to proceed even if the new Active Module is not fault free.

6. Specifications

Backplane (IMB) Supply	
Voltage	20 Vdc to 32 Vdc
Power	20 W
Field Supply	N/A
Maximum Power Dissipation	20 W
Module Location	T8100, T8300 I/O Module Slot
Isolation	
Field Common	50 V Reinforced (continuous) ⁽¹⁾ 250 V Basic (fault) ⁽²⁾ [Type tested at 2436 Vdc for 60 s].
Channel to Channel	None
Fusing	None
Number of Channels	60 Channels
Input	
Impedance (FTA)	5 kΩ
Measurement Range	±40 Vdc
Thresholds	Configurable
Maximum Withstanding	±50 Vdc
Safety Accuracy	0.5 Vdc Full Scale
Intrinsic Safety	None - External barrier required
Sequence of Events	
Event Resolution (LSB)	1 ms
Time-stamp Accuracy	±10 ms

External Power	
Expected current consumption @ 24 Vdc	4.8 mA per channel
Operating Temperature	0 °C to +60 °C (+32 °F to +140 °F)
Storage Temperature	-25 °C to +70 °C (-13 °F to +158 °F)
Relative Humidity – Operating and Storage	10 % – 95 %, non-condensing
Environmental Specifications	Refer to Document ICSTT-TD003
Dimensions	
Height	266 mm (10.5 in)
Width	31 mm (1.2 in)
Depth	303 mm (12.0 in)
Weight	1.16 kg (2.6 lb)

Note 1) 50 Vrms Secondary circuit derived from Mains, OVC II up to 300V.

Note 2) 250 Vrms Mains circuit, OVC II up to 300V. Exposure to voltages at these levels shall be temporally constrained consistent with the system MTTR.